

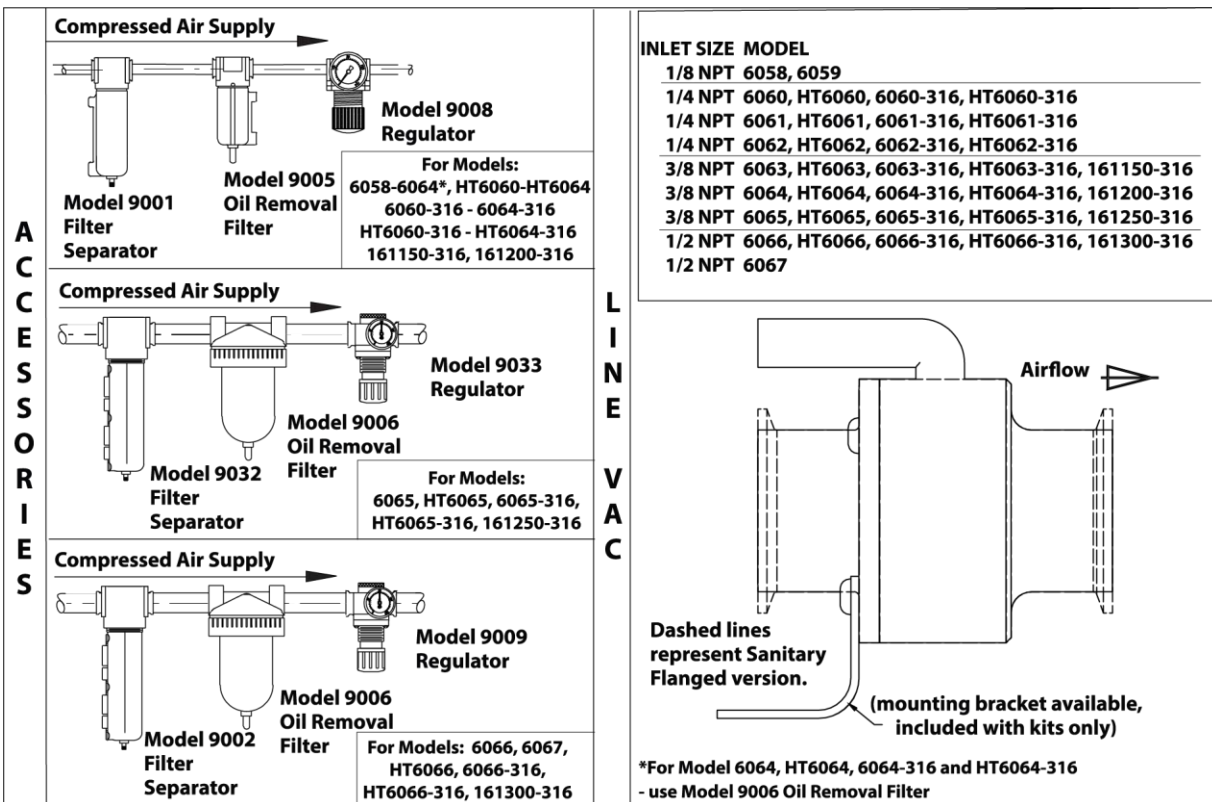

## LINE VAC™ (STAINLESS STEEL) INSTALLATION & MAINTENANCE



### COMPRESSED AIR LINE SIZES

For stainless steel models 6058-6064, 6060-316 – 6064-316, 161150-316, 161200-316, and high temperature models HT6060-HT6064, and HT6060-316 – HT6064-316 use 1/4" pipe or 3/8" hose for runs up to 25' (7.6m) long. For runs up to 50' (15.2m), use 3/8" pipe or 1/2" hose and for runs over 50' (15.2m), use 1/2" pipe or larger. For stainless steel models 6065-6067, 6065-316 – 6066-316, 161250-316, 161300-316, and high temperature models HT6065-HT6066, and HT6065-316 – HT6066-316, use 1/2" pipe or larger. Do not use restrictive fittings or undersized lines that can "starve" the Line Vac by causing excessive line pressure drop.

### COMPRESSED AIR SUPPLY

With proper filtration and separation of dirt, moisture and oil from the compressed air supply, the Line Vac will operate for years with no maintenance required.

Use a 10 micron or smaller filter separator on the compressed air supply (Model 9001 Automatic Drain Filter Separator for Models 6058-6064, 161150-316 – 161200-316, HT6060-HT6064, 6060-316 – 6064-316 and HT6060-316 – HT6064-316; Model 9032 Automatic Drain Filter Separator for Models 6065, 161250-316, HT6065 and HT6065-316; and Model 9002 Automatic Drain Filter Separator for Models 6066-6067, HT6066, 6066-316, 161300-316 and HT6066-316).

To prevent problems associated with oil, use an oil removal filter (Model 9005 Oil Removal Filter for Models 6058-6063, 161150-316, HT6060-HT6063, 6060-316 – 6063-316 and HT6060-316 – HT6063-316; Model 9006 Oil Removal Filter for Model 6064-6067, 161200-316 – 161300-316, HT6064-HT6066, 6064-316 – 6066-316 and HT6064-316 – HT6066-316). The oil removal filter should be used downstream from the automatic drain filter separator. Filters should be used close to each Line Vac, within 10' to 15' (3 to 4.6m) is best.

Line Vac is designed to use normal shop air supplies up to 100 PSIG (6.9 BAR, 689 kPa). For infinite control of flow (conveying speed), pressure may be regulated (Model 9008 Pressure Regulator for Model 6058-6064, Model 9033 Pressure Regulator for Model 6065 and Model 9009 Pressure Regulator for Models 6066 and 6067). Maximum pressure is 250 PSIG (17.2 BAR, 1.72 MPa).

If air preparation units other than EXAIR models are being used, please note the following:

- **PRESSURE REGULATORS** – Must be pressure relieving and rated for a supply pressure of 250 PSIG (17.2 BAR, 1.72 MPa). Suggested operating pressure is 5-125 PSIG (0.3-8.6 BAR, 34-862 kPa). For models 2" (51mm) and

under, flow should be minimum 50 SCFM (1416 SLPM). For models over 2" (51mm) and up to 4" (102mm), flow should be minimum 90 SCFM (2549 SLPM). For models over 4" (102mm), flow should be minimum 150 SCFM (4248 SLPM).

- **AUTO DRAIN FILTER SEPARATORS** – Must be rated for a supply pressure of 250 PSIG (17.2 BAR, 1.72 MPa) and have 25 micron filtration. For models 2" (51mm) and under, flow should be minimum 50 SCFM (1416 SLPM). For models over 2" (51mm) and up to 4" (102mm), flow should be minimum 90 SCFM (2549 SLPM). For models over 4" (102mm), flow should be minimum 150 SCFM (4248 SLPM).
- **OIL REMOVAL FILTERS** – Must be rated for a supply pressure of 250 PSIG (17.2 BAR, 1.72 MPa) and have 0.03 micron filtration. For models 2" (51mm) and under, flow should be minimum 50 SCFM (1416 SLPM). For models over 2" (51mm) and up to 4" (102mm), flow should be minimum 90 SCFM (2549 SLPM). For models over 4" (102mm), flow should be minimum 150 SCFM (4248 SLPM).

### USING LINE VAC

Mounting brackets are available for the Line Vac (included with kits only). In some cases, the Line Vac will be supported by the compressed air supply pipe.

Line Vac units are made in various sizes to be used with standard hose or tube. They perform best when mounted at the suction point, however, a hose or tube can be attached to either or both ends of the unit. Hose or tube should be straight when possible and bends minimized to reduce back pressure.

**WARNING:** Do not use with any material that can create an explosive mixture.

### HOW LINE VAC WORKS

Compressed air flows through the inlet (1) into an annular plenum chamber (2). It is then injected into the throat through directed nozzles (3). These jets of air create a vacuum at the intake (4) which draws material in and accelerates it through the unit (5) at long vertical or horizontal distances.

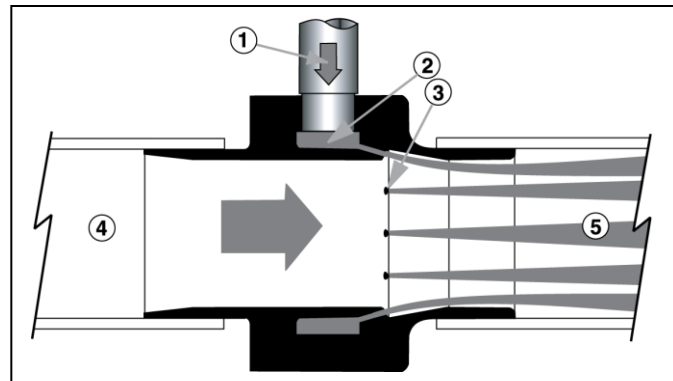

### ADJUSTING THE LINE VAC

The flow generators have a series of holes that convey the material. Conveying speed can be controlled with a pressure regulator. For greater speeds and conveying distances, the generator holes can be made larger with a drill (disassembly required - see "Cleaning"). It is recommended that all hole diameters be increased in 1/64" (.40mm) intervals and tested.

### TROUBLESHOOTING & MAINTENANCE

**If There Is A Reduction In Flow Or Vacuum From The Line Vac**, check the pressure by installing a gauge at the compressed air inlet of the Line Vac. Large pressure drops are possible due to undersized lines, restrictive fittings and clogged filter elements.

**For replacement or repair filter and regulator parts, contact MOWOTAS Thailand at +66 (0)90 124 8875 or contact-mowotasthailand@mowotas.com.**

### CLEANING

If contaminants have clogged the Line Vac, remove all screws to disassemble the unit. Inspect each part for dirt contamination and a possible oil film on the flow generator. Clean each part and reassemble. The Line Vac consists of a body, a flow generator, two O-rings and a cap that holds the flow generator in place. The screws that hold the assembly together are on the intake side of the unit. When reassembling, the small holes of the flow generator should point to the exhaust end.

Occasionally, there is a buildup which occurs in the throat of the Line Vac as a result of vapors in the atmosphere. Clean the surface with a solvent and a clean rag. To prevent contaminants from getting pushed back into the generator holes, perform this procedure with a small amount of compressed air passing through the Line Vac.

If you have any questions or problems, please contact:

**MOWOTAS (Thailand) Co. Ltd.**

228, Muhti 11

Nongprue, Banglamung

Chonburi, 20150 Thailand

Phone: +66 (0)90 124 8875

Email: [contact-mowotasthailand@mowotas.com](mailto:contact-mowotasthailand@mowotas.com)

Website: [www.mowotas.co.th](http://www.mowotas.co.th)

